

MORRIS™ FAMILY

Light fixture design inspired by William Morris, a founder of the Arts & Crafts movement. Clean, durable castings evoke one of the hallmarks of the movement in simplicity of form, without superfluous decoration.



**NEW
CLASSICS™**
Handmade in USA

MORRIS™ FAMILY

INTERIOR LIGHTING FIXTURES

brasslightgallery.com 800-243-9595 sales@brasslight.com

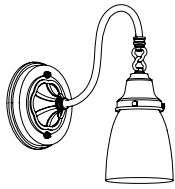

CN-105-D9

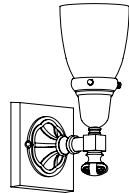

CN-176-A4

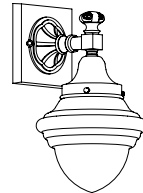

CN-176-A5

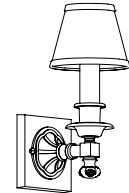

CN-176-K1

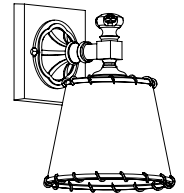

CN-176-K8

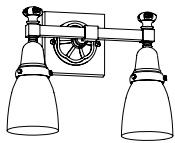

CN-177-A4

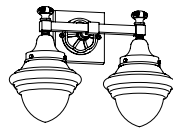

CN-177-A5

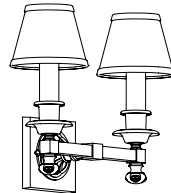

CN-177-K1

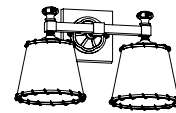

CN-177-K8

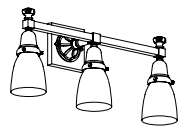

CN-178-A4

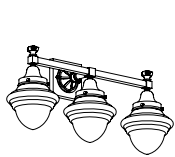

CN-178-A5

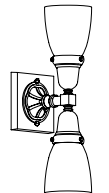

CN-179-A4

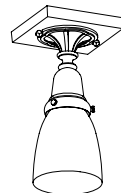

CN-521-A4



CN-521-A5



CN-522-A4-03M

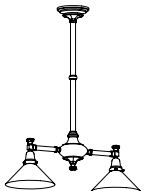

CN-523-A4-03M

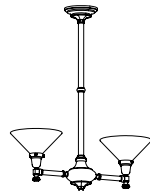

CN-523-A4-09M

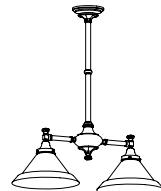

CN-523-A5-03M

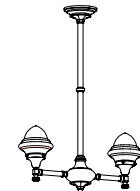

CN-523-A5-09M

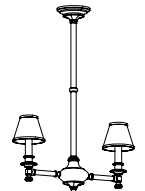

CN-523-K2-09M

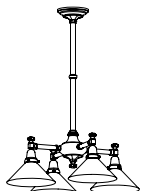

CN-524-A4-03M

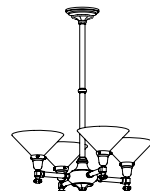

CN-524-A4-09M

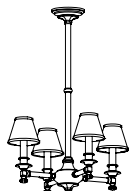

CN-524-K2-09M

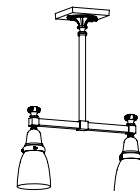

CN-576-A4-03M

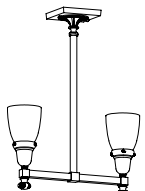

CN-576-A4-09M

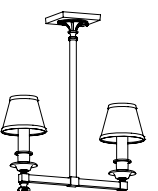

CN-576-K1-09M

Morris Family v2.0 page 2

MORRIS™ ONE LIGHT CURVED ARM SCONCE

WITH 2-1/4" SHADE HOLDER

brasslightgallery.com 800-243-9595 sales@brasslight.com

Morris Family v2.0 page 3

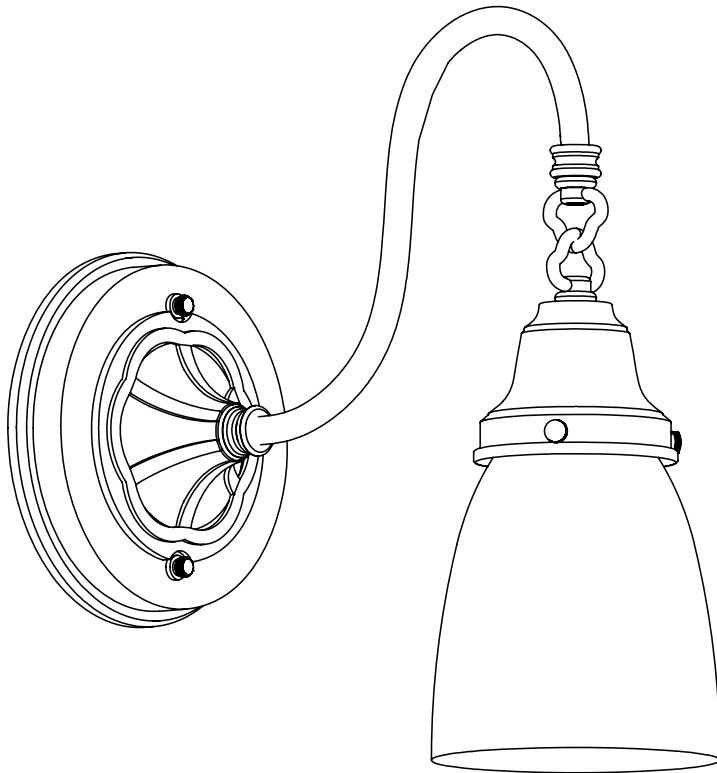

**NEW
CLASSICS™**
Handmade in USA

FINISHES - applied by hand.

| | |
|-----------------|------------------------|
| Polished Nickel | Architectural Bronze |
| Brushed Nickel | Verdigris Patina |
| Black | Distressed Brass |
| Brushed Brass | Antique Copper |
| Polished Brass | Satin Antique Brass |
| Antique Nickel | Unlacquered Pol. Brass |
| Vintage Nickel | Architectural Iron |

CN-105-D9 Shown with A157 shade(s)

Medium base screw-in socket (1) accepts 150 W max incandescent, compact fluorescent, or LED.

GU24 base bi-pin socket available. 277V 4 pin socket alternative, inquire. Check our website for alternative 2-1/4" shades.

Mounting plate center mounts to junction box.

Mount down only.

UL listed dry location.

Durably constructed of solid brass.

Made in USA by Brass Light Gallery.

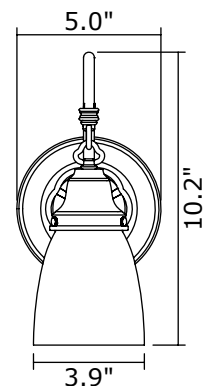
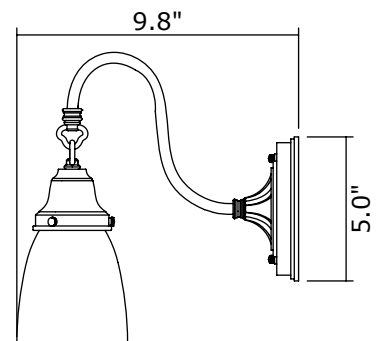

BRASS LIGHT GALLERY
• MILWAUKEE •

© 2013, Brass Light Gallery®

MORRIS™ ONE LIGHT STRAIGHT ARM SCONCE

WITH 2-1/4" SHADE HOLDER

brasslightgallery.com 800-243-9595 sales@brasslight.com

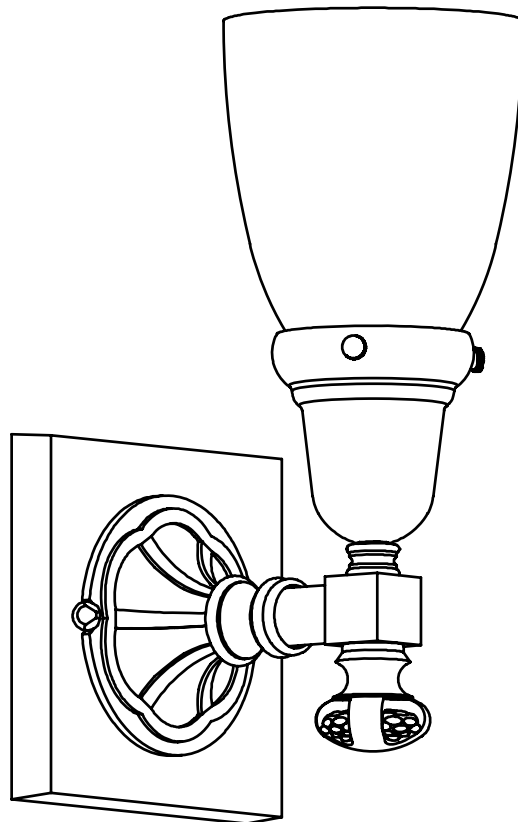

**NEW
CLASSICS™**
Handmade in USA

FINISHES - applied by hand.

| | |
|-----------------|------------------------|
| Polished Nickel | Architectural Bronze |
| Brushed Nickel | Verdigris Patina |
| Black | Distressed Brass |
| Brushed Brass | Antique Copper |
| Polished Brass | Satin Antique Brass |
| Antique Nickel | Unlacquered Pol. Brass |
| Vintage Nickel | Architectural Iron |

CN-176-A4 Shown with A157 shade(s)

Medium base screw-in socket et (1) accepts 150 W max incandescent, compact fluorescent, or LED.

GU24 base bi-pin socket a available. 277V 4 pin sock et alternative, inquire.

Check our website for alternative 2-1/4" shades.

Mounting plate center mounts to junction box.

Mount glass up or glass down.

UL listed dry location. Damp location available, inquire.

Durably constructed of solid brass.

Made in USA by Brass Light Gallery.

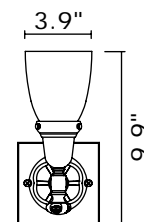
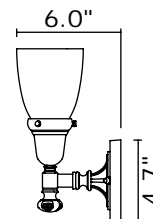

Morris Family v2.0 page 4

BRASS LIGHT GALLERY
• MILWAUKEE •

© 2013, Brass Light Gallery®

MORRIS™ ONE LIGHT STRAIGHT ARM SCONCE

WITH ELECTRIC CANDLE

brasslightgallery.com 800-243-9595 sales@brasslight.com

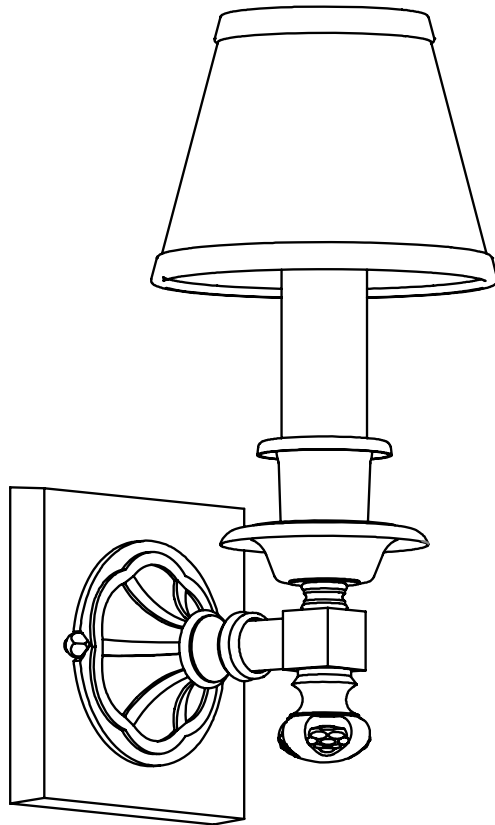

**NEW
CLASSICS™**
Handmade in USA

FINISHES - applied by hand.

| | |
|-----------------|------------------------|
| Polished Nickel | Architectural Bronze |
| Brushed Nickel | Verdigris Patina |
| Black | Distressed Brass |
| Brushed Brass | Antique Copper |
| Polished Brass | Satin Antique Brass |
| Antique Nickel | Unlacquered Pol. Brass |
| Vintage Nickel | Architectural Iron |

CN-176-K1 Shown with E231 shade(s)

Medium base screw-in socket (1) accepts 60 W max incandescent, compact fluorescent, or LED.

GU24 base bi-pin socket available. 277V 4 pin socket alternative, inquire.

Check online for alternative clip-on shades rated at 40 to 100 watts with this fixture.

Mounting plate center mounts to junction box.

Mount candle up.

UL listed dry location.

Durably constructed of solid brass.

Made in USA by Brass Light Gallery.

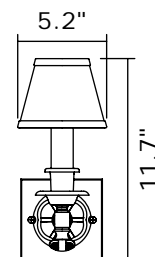
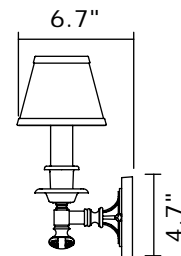

Morris Family v2.0 page 5

MORRIS™ ONE LIGHT STRAIGHT ARM SCONCE

WITH 3-1/4" SHADE HOLDER

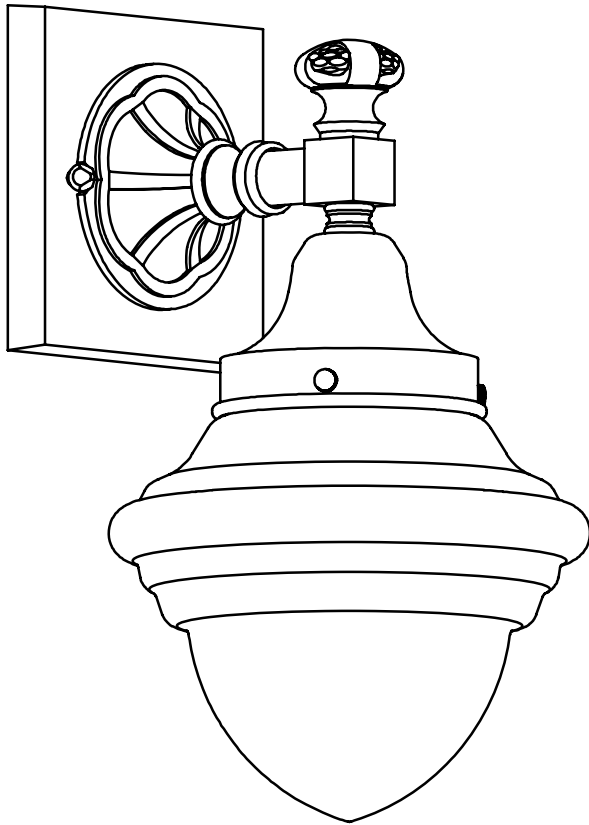

**NEW
CLASSICS™**
Handmade in USA

FINISHES - applied by hand.

| | |
|-----------------|------------------------|
| Polished Nickel | Architectural Bronze |
| Brushed Nickel | Verdigris Patina |
| Black | Distressed Brass |
| Brushed Brass | Antique Copper |
| Polished Brass | Satin Antique Brass |
| Antique Nickel | Unlacquered Pol. Brass |
| Vintage Nickel | Architectural Iron |

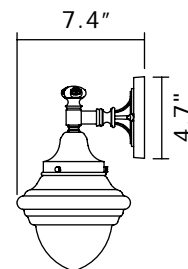

CN-176-A5 Shown with B141 shade(s)

Medium base screw-in socket et (1) accepts 150 W max incandescent, compact fluorescent, or LED.

GU24 base bi-pin socket a available. 277V 4 pin socket et alternative, inquire.

Check our website for alternative 3-1/4" shades.

Mounting plate center mounts to junction box.

Mount glass up or glass down.

UL listed dry location. Damp location available, inquire.

Durably constructed of solid brass.

Made in USA by Brass Light Gallery.

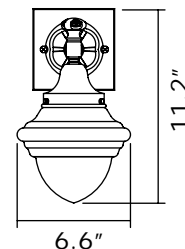

MORRIS™ ONE LIGHT STRAIGHT ARM SCONCE

WITH O-RING SHADE HOLDER

**NEW
CLASSICS™**
Handmade in USA

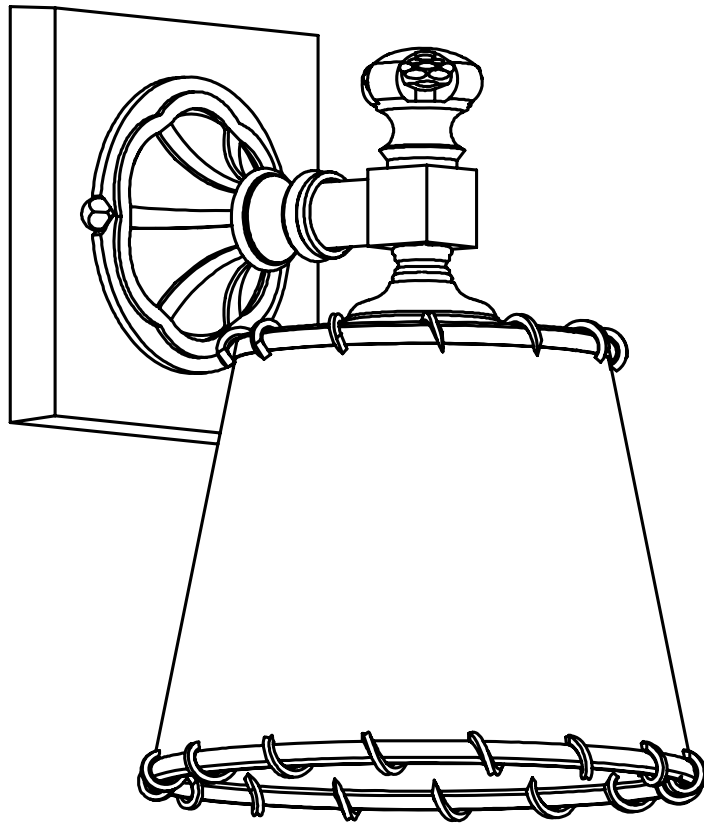

FINISHES - applied by hand.

| | |
|-----------------|------------------------|
| Polished Nickel | Architectural Bronze |
| Brushed Nickel | Verdigris Patina |
| Black | Distressed Brass |
| Brushed Brass | Antique Copper |
| Polished Brass | Satin Antique Brass |
| Antique Nickel | Unlacquered Pol. Brass |
| Vintage Nickel | Architectural Iron |

CN-176-K8 Shown with R531 shade(s)

Medium base screw-in socket (1) accepts 60 W max incandescent, compact fluorescent, or LED.

GU24 base bi-pin socket available. 277V 4 pin socket alternative, inquire.

Check online for alternative clip-on shades rated at 40 to 100 watts with this fixture.

Mounting plate center mounts to junction box.

Mount down only.

Durably constructed of solid brass.

Made in USA by Brass Light Gallery.

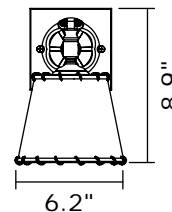
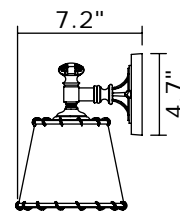

MORRIS™ TWO LIGHT STRAIGHT ARM SCONCE

WITH 2-1/4" SHADE HOLDERS

brasslightgallery.com 800-243-9595 sales@brasslight.com

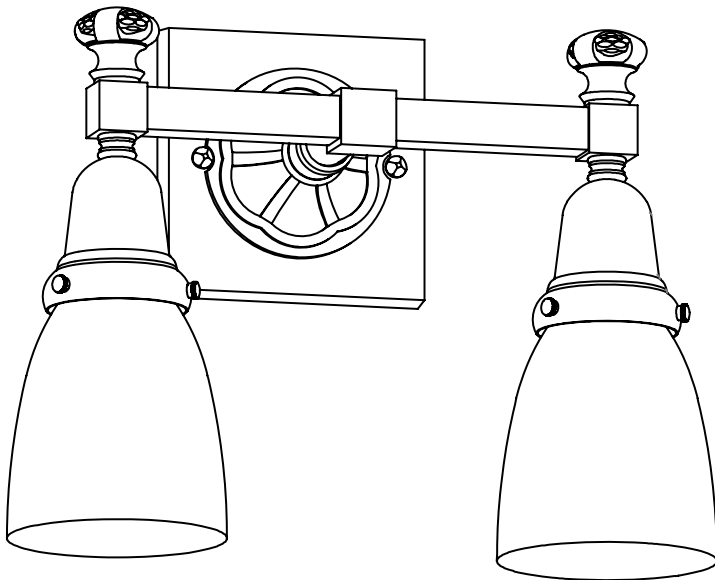

**NEW
CLASSICS™**
Handmade in USA

FINISHES - applied by hand.

| | |
|-----------------|------------------------|
| Polished Nickel | Architectural Bronze |
| Brushed Nickel | Verdigris Patina |
| Black | Distressed Brass |
| Brushed Brass | Antique Copper |
| Polished Brass | Satin Antique Brass |
| Antique Nickel | Unlacquered Pol. Brass |
| Vintage Nickel | Architectural Iron |

CN-177-A4 Shown with A157 shade(s)

Medium base screw-in sockets (2) each accept 150 W max incandescent, compact fluorescent, or LED.

GU24 base bi-pin socket available. 277V 4 pin socket alternative, inquire.

Check our website for alternative 2-1/4" shades.

Mounting plate center mounts to junction box.

Mount glass up or glass down.

UL listed dry location. Damp location available, inquire.

Durably constructed of solid brass.

Made in USA by Brass Light Gallery.

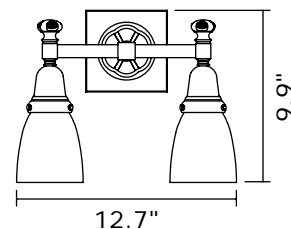
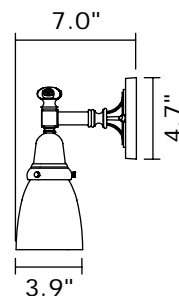

Morris Family v2.0 page 8

MORRIS™ TWO LIGHT STRAIGHT ARM SCONCE

WITH 3-1/4" SHADE HOLDERS

brasslightgallery.com 800-243-9595 sales@brasslight.com

Morris Family v2.0 page 9

**NEW
CLASSICS™**
Handmade in USA

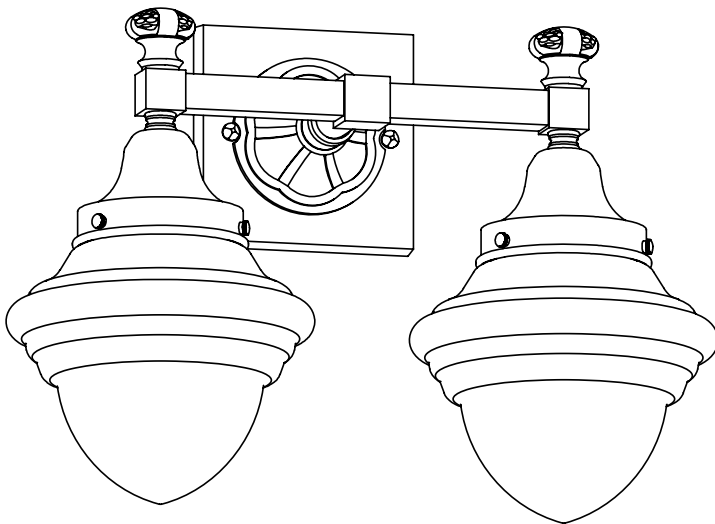

FINISHES - applied by hand.

| | |
|-----------------|------------------------|
| Polished Nickel | Architectural Bronze |
| Brushed Nickel | Verdigris Patina |
| Black | Distressed Brass |
| Brushed Brass | Antique Copper |
| Polished Brass | Satin Antique Brass |
| Antique Nickel | Unlacquered Pol. Brass |
| Vintage Nickel | Architectural Iron |

CN-177-A5 Shown with B141 shade(s)

Medium base screw-in sockets (2) each accept 150 W max incandescent, compact fluorescent, or LED.

GU24 base bi-pin socket available. 277V 4 pin socket alternative, inquire.

Check our website for alternative 3-1/4" shades.

Mounting plate center mounts to junction box.

Mount glass up or glass down.

UL listed dry location. Damp location available, inquire.

Durably constructed of solid brass.

Made in USA by Brass Light Gallery.

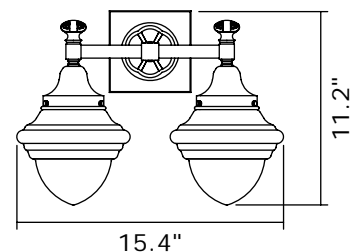
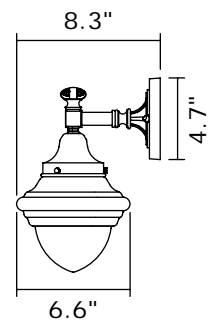

MORRIS™ TWO LIGHT STRAIGHT ARM SCONCE

WITH ELECTRIC CANDLES

brasslightgallery.com 800-243-9595 sales@brasslight.com

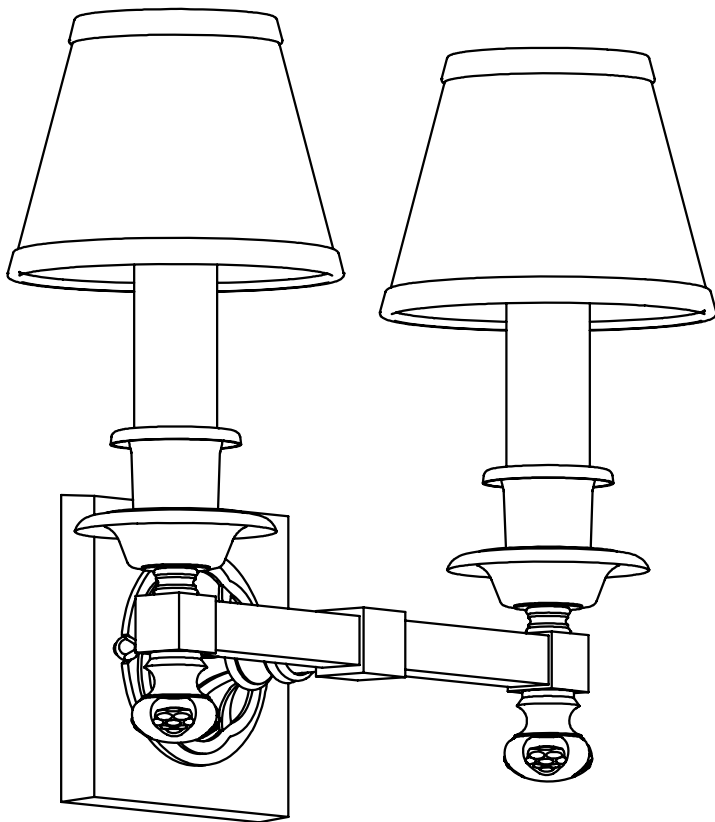

**NEW
CLASSICS™**
Handmade in USA

FINISHES - applied by hand.

| | |
|-----------------|------------------------|
| Polished Nickel | Architectural Bronze |
| Brushed Nickel | Verdigris Patina |
| Black | Distressed Brass |
| Brushed Brass | Antique Copper |
| Polished Brass | Satin Antique Brass |
| Antique Nickel | Unlacquered Pol. Brass |
| Vintage Nickel | Architectural Iron |

CN-177-K1 Shown with E231 shade(s)

Medium base screw-in sockets (2) each accept 60 W max incandescent, compact fluorescent, or LED.

GU24 base bi-pin socket available. 277V 4 pin socket alternative, inquire.

Check online for alternative clip-on shades rated at 40 to 100 watts with this fixture.

Mounting plate center mounts to junction box.

Mount candle up.

UL listed dry location.

Durably constructed of solid brass.

Made in USA by Brass Light Gallery.

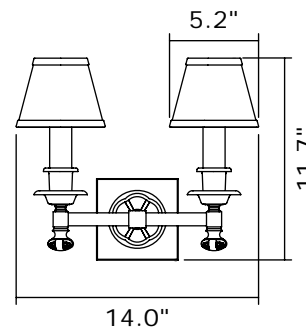
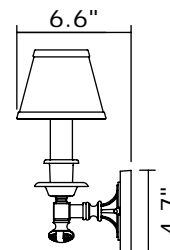

Morris Family v2.0 page 10

MORRIS™ TWO LIGHT STRAIGHT ARM SCONCE

WITH O-RING SHADE HOLDERS

brasslightgallery.com 800-243-9595 sales@brasslight.com

Morris Family v2.0 page 11

**NEW
CLASSICS™**
Handmade in USA

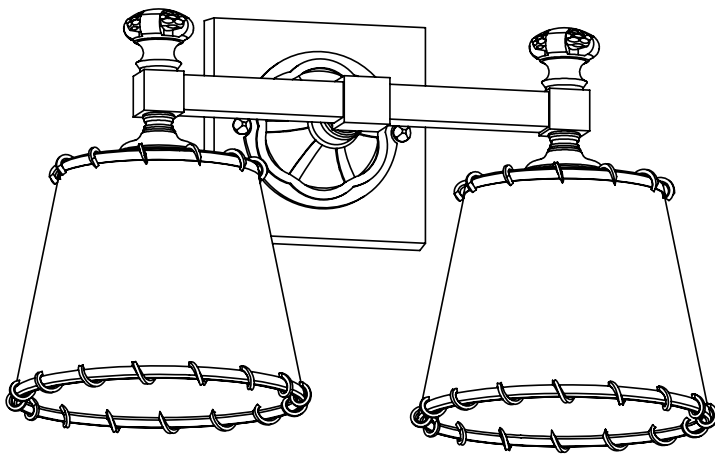

FINISHES - applied by hand.

| | |
|-----------------|------------------------|
| Polished Nickel | Architectural Bronze |
| Brushed Nickel | Verdigris Patina |
| Black | Distressed Brass |
| Brushed Brass | Antique Copper |
| Polished Brass | Satin Antique Brass |
| Antique Nickel | Unlacquered Pol. Brass |
| Vintage Nickel | Architectural Iron |

CN-177-K8 Shown with R531 shade(s)

Medium base screw-in sockets (2) each accept 60 W max incandescent, compact fluorescent, or LED.

GU24 base bi-pin socket available. 277V 4 pin socket alternative, inquire.

Check online for alternative clip-on shades rated at 40 to 100 watts with this fixture.

Mounting plate center mounts to junction box.

Mount down only.

Durably constructed of solid brass.

Made in USA by Brass Light Gallery.

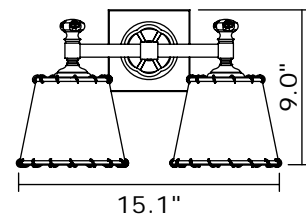
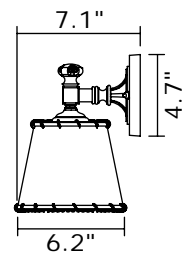

MORRIS™ THREE LIGHT STRAIGHT ARM SCONCE

WITH 2-1/4" SHADE HOLDERS

brasslightgallery.com 800-243-9595 sales@brasslight.com

Morris Family v2.0 page 12

**NEW
CLASSICS™**
Handmade in USA

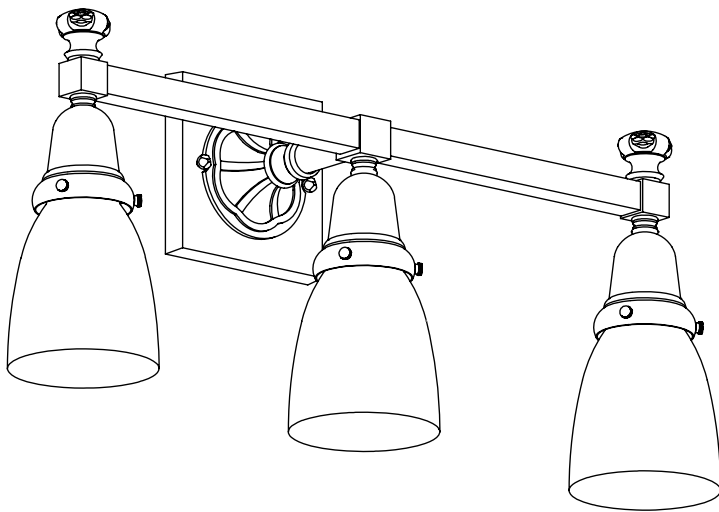

FINISHES - applied by hand.

| | |
|-----------------|------------------------|
| Polished Nickel | Architectural Bronze |
| Brushed Nickel | Verdigris Patina |
| Black | Distressed Brass |
| Brushed Brass | Antique Copper |
| Polished Brass | Satin Antique Brass |
| Antique Nickel | Unlacquered Pol. Brass |
| Vintage Nickel | Architectural Iron |

CN-178-A4 Shown with A157 shade(s)

Medium base screw-in sockets (3) each accept 150 W max incandescent, compact fluorescent, or LED.

GU24 base bi-pin socket available. 277V 4 pin socket alternative, inquire.

Check our website for alternative 2-1/4" shades.

Mounting plate center mounts to junction box.

Mount glass up or glass down.

UL listed dry location. Damp location available, inquire.

Durably constructed of solid brass.

Made in USA by Brass Light Gallery.

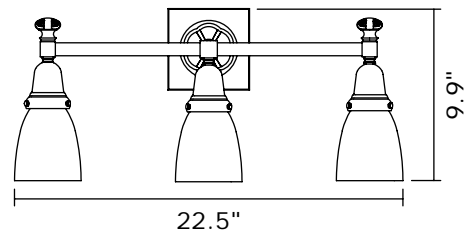
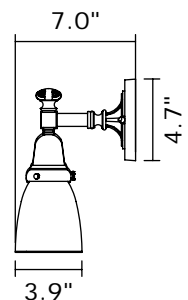

MORRIS™ THREE LIGHT STRAIGHT ARM SCONCE

WITH 3-1/4" SHADE HOLDERS

brasslightgallery.com 800-243-9595 sales@brasslight.com

Morris Family v2.0 page 13

**NEW
CLASSICS™**
Handmade in USA

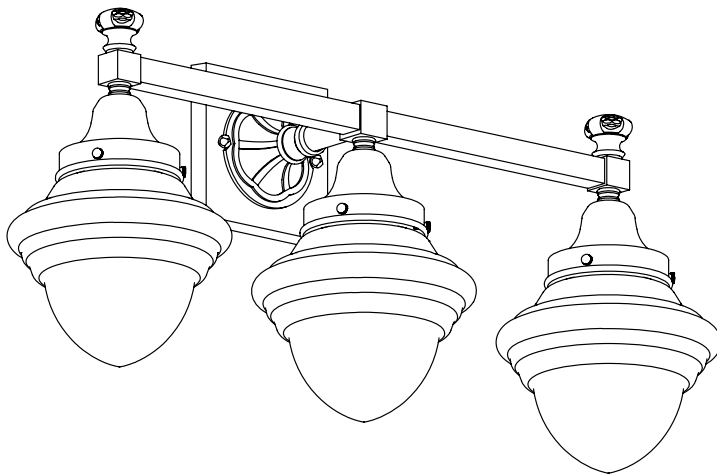

FINISHES - applied by hand.

| | |
|-----------------|------------------------|
| Polished Nickel | Architectural Bronze |
| Brushed Nickel | Verdigris Patina |
| Black | Distressed Brass |
| Brushed Brass | Antique Copper |
| Polished Brass | Satin Antique Brass |
| Antique Nickel | Unlacquered Pol. Brass |
| Vintage Nickel | Architectural Iron |

CN-178-A5 Shown with B141 shade(s)

Medium base screw-in sockets (3) each accept 150 W max incandescent, compact fluorescent, or LED.

GU24 base bi-pin socket available. 277V 4 pin socket alternative, inquire.

Check our website for alternative 3-1/4" shades.

Mounting plate center mounts to junction box.

Mount glass up or glass down.

UL listed dry location. Damp location available, inquire.

Durably constructed of solid brass.

Made in USA by Brass Light Gallery.

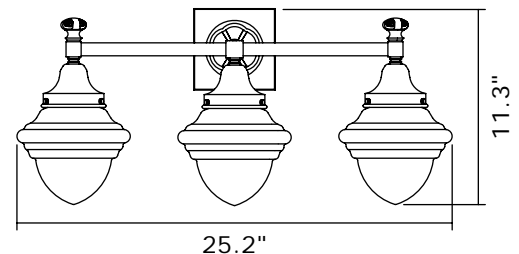
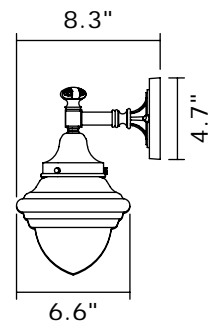

BRASS LIGHT GALLERY
• MILWAUKEE •

© 2013, Brass Light Gallery®

MORRIS™ TWO LIGHT LINEAR SCONCE

WITH 2-1/4" SHADE HOLDERS

brasslightgallery.com 800-243-9595 sales@brasslight.com

Morris Family v2.0 page 14

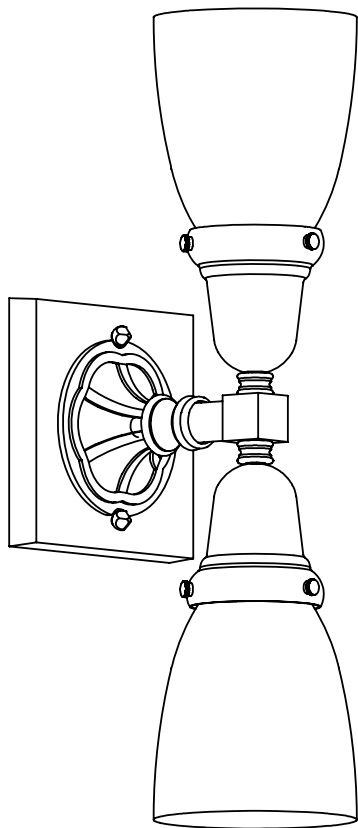

**NEW
CLASSICS™**
Handmade in USA

FINISHES - applied by hand.

| | |
|-----------------|------------------------|
| Polished Nickel | Architectural Bronze |
| Brushed Nickel | Verdigris Patina |
| Black | Distressed Brass |
| Brushed Brass | Antique Copper |
| Polished Brass | Satin Antique Brass |
| Antique Nickel | Unlacquered Pol. Brass |
| Vintage Nickel | Architectural Iron |

CN-179-A4 Shown with A157 shade(s)

Medium base screw-in sockets (2) each accept 150 W max incandescent, compact fluorescent, or LED.

GU24 base bi-pin socket available. 277V 4 pin socket alternative, inquire.

Check our website for alternative 2-1/4" shades.

Mounting plate center mounts to junction box.

Mount horizontally or vertically.

UL listed dry location. Damp location available, inquire.

Durably constructed of solid brass.

Made in USA by Brass Light Gallery.

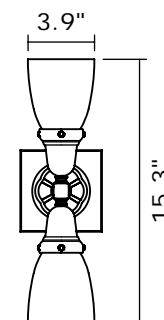
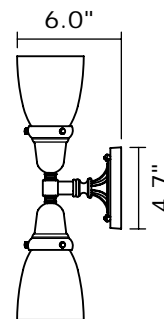

BRASS LIGHT GALLERY
• MILWAUKEE •

© 2013, Brass Light Gallery®

MORRIS™ ONE LIGHT SEMI FLUSH CEILING FIXTURE

WITH 2-1/4" SHADE HOLDER

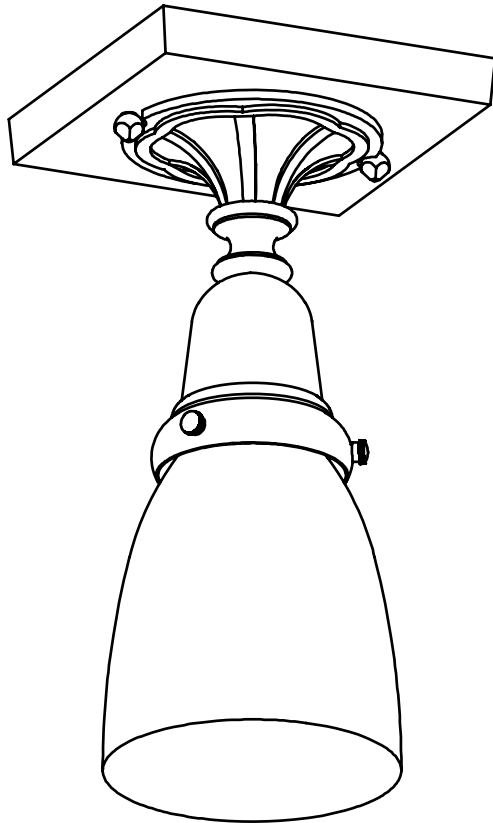

**NEW
CLASSICS™**
Handmade in USA

FINISHES - applied by hand.

| | |
|-----------------|------------------------|
| Polished Nickel | Architectural Bronze |
| Brushed Nickel | Verdigris Patina |
| Black | Distressed Brass |
| Brushed Brass | Antique Copper |
| Polished Brass | Satin Antique Brass |
| Antique Nickel | Unlacquered Pol. Brass |
| Vintage Nickel | Architectural Iron |

CN-521-A4 Shown with A157 shade(s)

Medium base screw-in socket (1) accepts 150 W max incandescent, compact fluorescent, or LED.

GU24 base bi-pin socket available. 277V 4 pin socket alternative, inquire.

Check our website for alternative 2-1/4" shades.

Mounting plate center mounts to junction box.

Angled ceiling version available, inquire.

UL listed dry location. Damp location available, inquire.

Durably constructed of solid brass.

Made in USA by Brass Light Gallery.

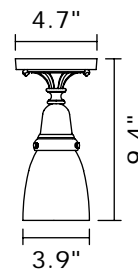

MORRIS™ ONE LIGHT SEMI FLUSH CEILING FIXTURE

WITH 3-1/4" SHADE HOLDER

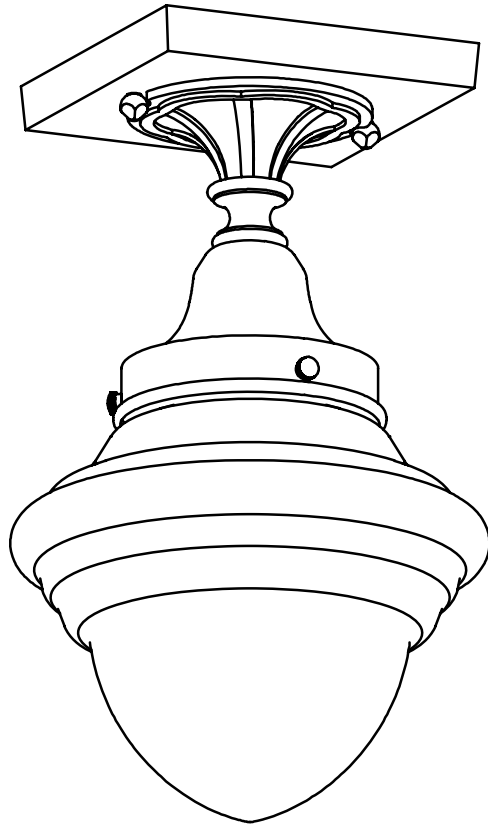

**NEW
CLASSICS™**
Handmade in USA

FINISHES - applied by hand.

| | |
|-----------------|------------------------|
| Polished Nickel | Architectural Bronze |
| Brushed Nickel | Verdigris Patina |
| Black | Distressed Brass |
| Brushed Brass | Antique Copper |
| Polished Brass | Satin Antique Brass |
| Antique Nickel | Unlacquered Pol. Brass |
| Vintage Nickel | Architectural Iron |

CN-521-A5 Shown with B141 shade(s)

Medium base screw-in socket (1) accepts 150 W max incandescent, compact fluorescent, or LED.

GU24 base bi-pin socket available. 277V 4 pin socket alternative, inquire.

Check our website for alternative 3-1/4" shades.

Mounting plate center mounts to junction box.

Angled ceiling version available, inquire.

UL listed dry location. Damp location available, inquire.

Durably constructed of solid brass.

Made in USA by Brass Light Gallery.

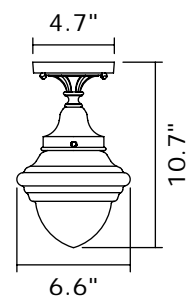

MORRIS™ ONE LIGHT PENDANT

WITH 2-1/4" SHADE HOLDER

brasslightgallery.com 800-243-9595 sales@brasslight.com

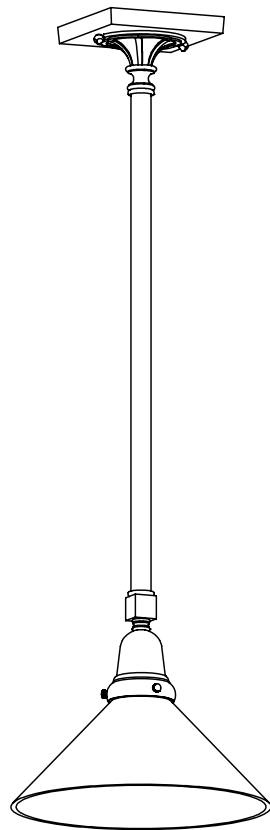

**NEW
CLASSICS™**
Handmade in USA

FINISHES - applied by hand.

| | |
|-----------------|------------------------|
| Polished Nickel | Architectural Bronze |
| Brushed Nickel | Verdigris Patina |
| Black | Distressed Brass |
| Brushed Brass | Antique Copper |
| Polished Brass | Satin Antique Brass |
| Antique Nickel | Unlacquered Pol. Brass |
| Vintage Nickel | Architectural Iron |

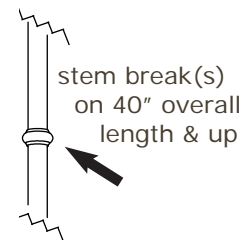

CN-522-A4-03M Shown with A384 shade(s)

Medium base screw-in socket (1) accepts 150 W max incandescent, compact fluorescent, or LED.

GU24 base bi-pin socket available. 277V 4 pin socket alternative, inquire.

Check our website for alternative 2-1/4" shades.

Mounting plate center mounts to junction box.

Specify overall length. Minimum overall length 12".

Angled ceiling version available, inquire.

UL listed dry location. Damp location available, inquire.

Durably constructed of solid brass.

Made in USA by Brass Light Gallery.

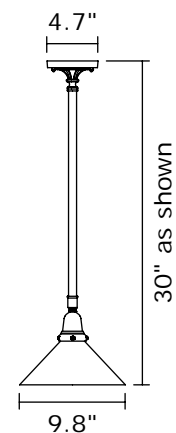

Morris Family v2.0 page 17

MORRIS™ TWO LIGHT CHANDELIER

WITH 2-1/4" SHADE HOLDERS DOWN

brasslightgallery.com 800-243-9595 sales@brasslight.com

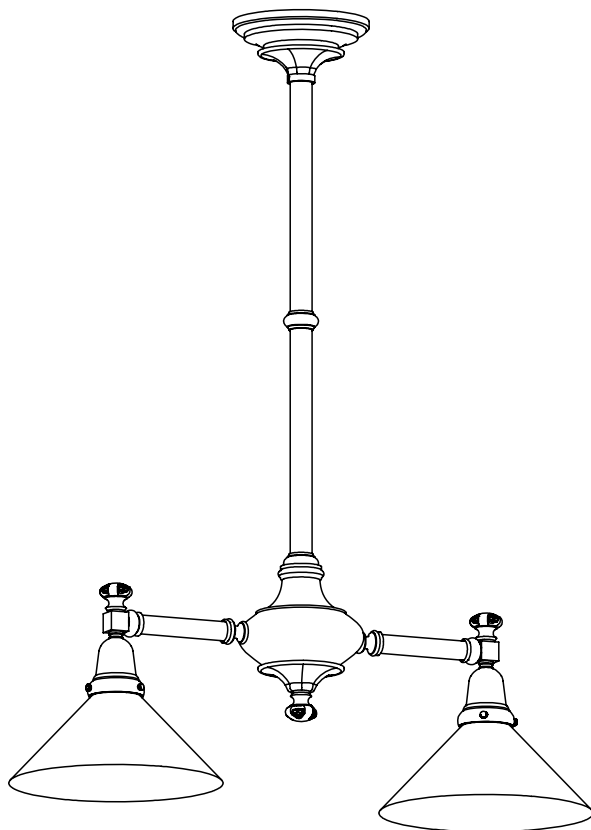

FINISHES - applied by hand.

| | |
|-----------------|------------------------|
| Polished Nickel | Architectural Bronze |
| Brushed Nickel | Verdigris Patina |
| Black | Distressed Brass |
| Brushed Brass | Antique Copper |
| Polished Brass | Satin Antique Brass |
| Antique Nickel | Unlacquered Pol. Brass |
| Vintage Nickel | Architectural Iron |

CN-523-A4-03M Shown with A384 shade(s)

Medium base screw-in sockets (2) each accept 150 W max incandescent, compact fluorescent, or LED.

GU24 base bi-pin socket available. 277V 4 pin socket alternative, inquire.

Check our website for alternative 2-1/4" shades.

Mounting plate center mounts to junction box.

Specify overall length. Minimum overall length 17".

Angled ceiling version available, inquire.

UL listed dry location.

Durably constructed of solid brass.

Made in USA by Brass Light Gallery.

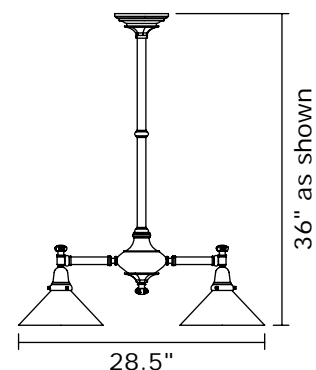
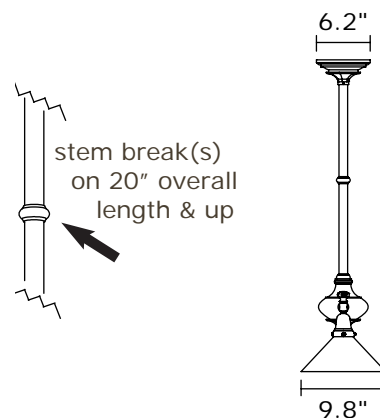

Morris Family v2.0 page 18

MORRIS™ TWO LIGHT CHANDELIER

WITH 2-1/4" SHADE HOLDERS UP

brasslightgallery.com 800-243-9595 sales@brasslight.com

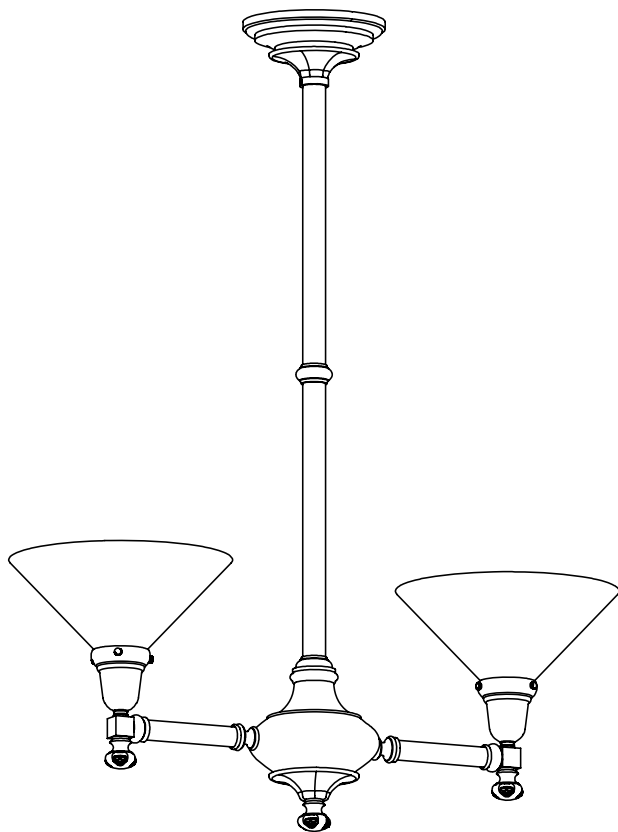

NEW CLASSICS™
Handmade in USA

FINISHES - applied by hand.

- | | |
|-----------------|------------------------|
| Polished Nickel | Architectural Bronze |
| Brushed Nickel | Verdigris Patina |
| Black | Distressed Brass |
| Brushed Brass | Antique Copper |
| Polished Brass | Satin Antique Brass |
| Antique Nickel | Unlacquered Pol. Brass |
| Vintage Nickel | Architectural Iron |

CN-523-A4-09M Shown with A384 shade(s)

Medium base screw-in sockets (2) each accept 150 W max incandescent, compact fluorescent, or LED.

GU24 base bi-pin socket available. 277V 4 pin socket alternative, inquire.

Check our website for alternative 2-1/4" shades.

Mounting plate center mounts to junction box.

Specify overall length. Minimum overall length 15".

Angled ceiling version available, inquire.

UL listed dry location.

Durably constructed of solid brass.

Made in USA by Brass Light Gallery.

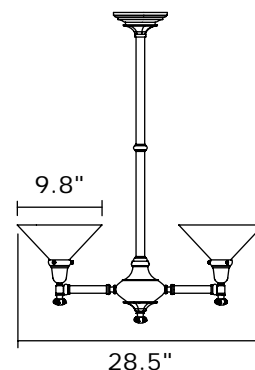
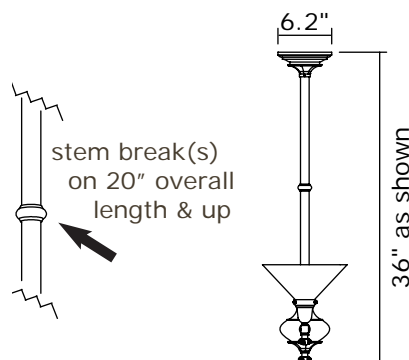

Morris Family v2.0 page 19

MORRIS™ TWO LIGHT CHANDELIER

WITH 3-1/4" SHADE HOLDERS DOWN

brasslightgallery.com 800-243-9595 sales@brasslight.com

NEW CLASSICS™
Handmade in USA

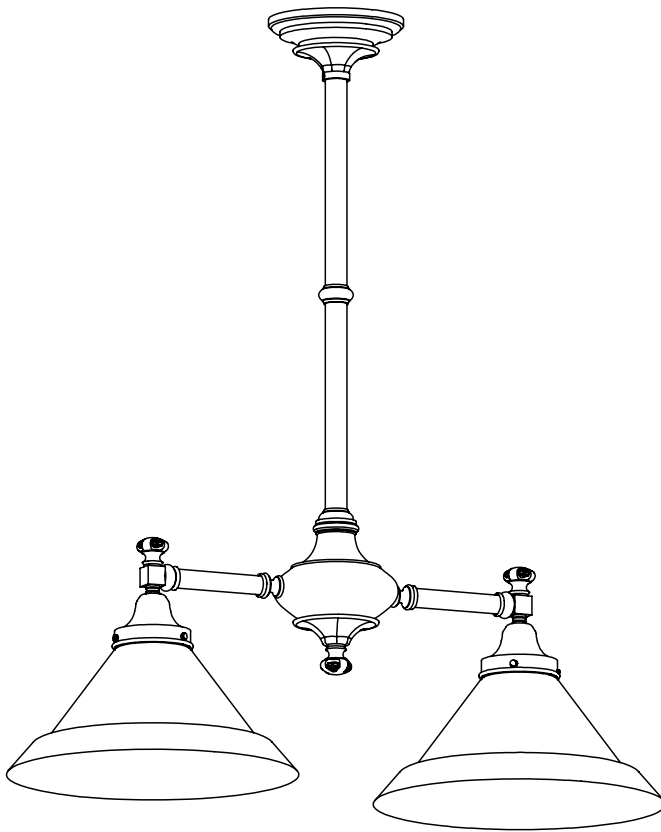

FINISHES - applied by hand.

| | |
|-----------------|------------------------|
| Polished Nickel | Architectural Bronze |
| Brushed Nickel | Verdigris Patina |
| Black | Distressed Brass |
| Brushed Brass | Antique Copper |
| Polished Brass | Satin Antique Brass |
| Antique Nickel | Unlacquered Pol. Brass |
| Vintage Nickel | Architectural Iron |

CN-523-A5-03M Shown with B409 shade(s)

Medium base screw-in sockets (2) each accept 150 W max incandescent, compact fluorescent, or LED.

GU24 base bi-pin socket available. 277V 4 pin socket alternative, inquire.

Check our website for alternative 3-1/4" shades.

Mounting plate center mounts to junction box.

Specify overall length. Minimum overall length 17".

Angled ceiling version available, inquire.

UL listed dry location.

Durably constructed of solid brass.

Made in USA by Brass Light Gallery.

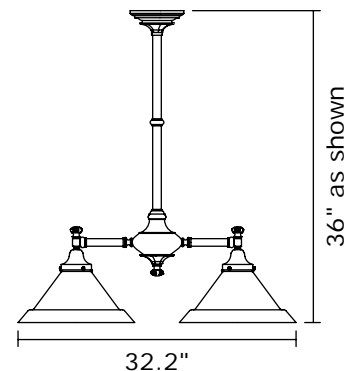
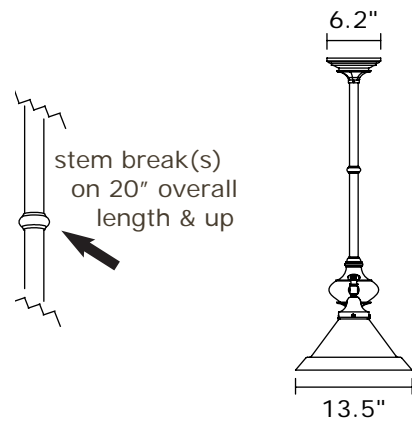

Morris Family v2.0 page 20

MORRIS™ TWO LIGHT CHANDELIER

WITH 3-1/4" SHADE HOLDERS UP

brasslightgallery.com 800-243-9595 sales@brasslight.com

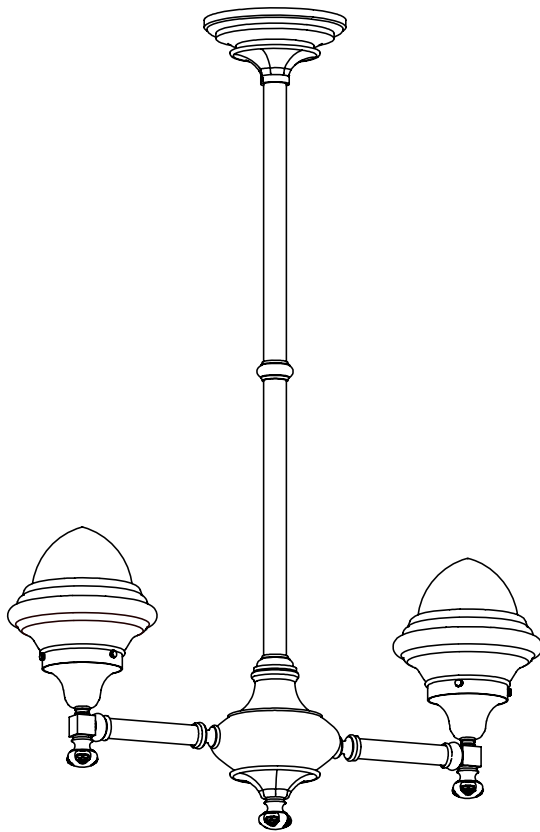

FINISHES - applied by hand.

| | |
|-----------------|------------------------|
| Polished Nickel | Architectural Bronze |
| Brushed Nickel | Verdigris Patina |
| Black | Distressed Brass |
| Brushed Brass | Antique Copper |
| Polished Brass | Satin Antique Brass |
| Antique Nickel | Unlacquered Pol. Brass |
| Vintage Nickel | Architectural Iron |

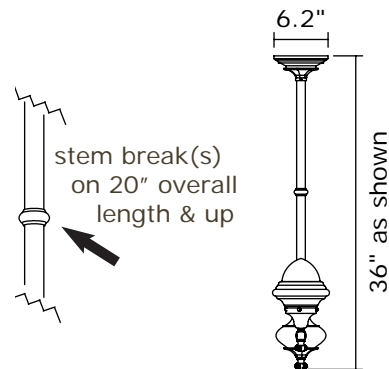

CN-523-A5-09M Shown with B141 shade(s)

Medium base screw-in sockets (2) each accept 150 W max incandescent, compact fluorescent, or LED.

GU24 base bi-pin socket available. 277V 4 pin socket alternative, inquire.

Check our website for alternative 3-1/4" shades.

Mounting plate center mounts to junction box.

Specify overall length. Minimum overall length 15".

Angled ceiling version available, inquire.

UL listed dry location.

Durably constructed of solid brass.

Made in USA by Brass Light Gallery.

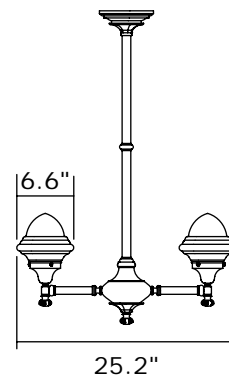

Morris Family v2.0 page 21

MORRIS™ TWO LIGHT CHANDELIER

WITH ELECTRIC CANDLES

brasslightgallery.com 800-243-9595 sales@brasslight.com

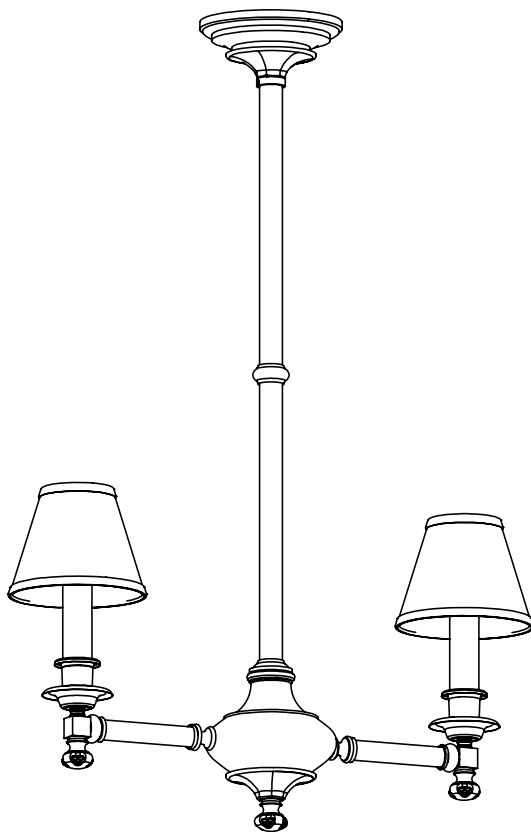

FINISHES - applied by hand.

| | |
|-----------------|------------------------|
| Polished Nickel | Architectural Bronze |
| Brushed Nickel | Verdigris Patina |
| Black | Distressed Brass |
| Brushed Brass | Antique Copper |
| Polished Brass | Satin Antique Brass |
| Antique Nickel | Unlacquered Pol. Brass |
| Vintage Nickel | Architectural Iron |

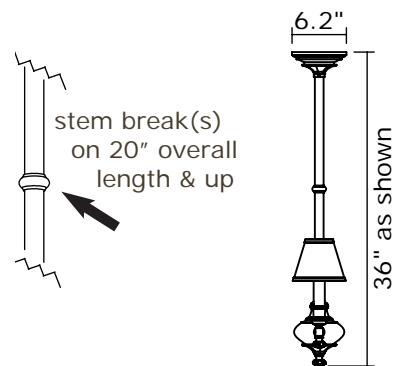

CN-523-K2-09M Shown with E210 shade(s)

Medium base screw-in sockets (2) each accept 60 W max incandescent, compact fluorescent, or LED.

GU24 base bi-pin socket available. 277V 4 pin socket alternative, inquire.

Check online for alternative clip-on shades rated at 40 to 100 watts with this fixture.

Mounting plate center mounts to junction box.

Specify overall length. Minimum overall length 19".

Angled ceiling version available, inquire.

UL listed dry location.

Durably constructed of solid brass.

Made in USA by Brass Light Gallery.

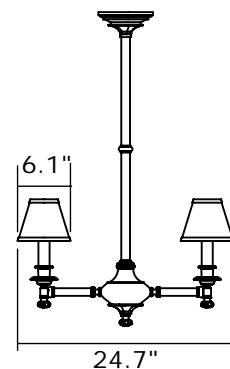

Morris Family v2.0 page 22

MORRIS™ FOUR LIGHT CHANDELIER

WITH 2-1/4" SHADE HOLDERS DOWN

brasslightgallery.com 800-243-9595 sales@brasslight.com

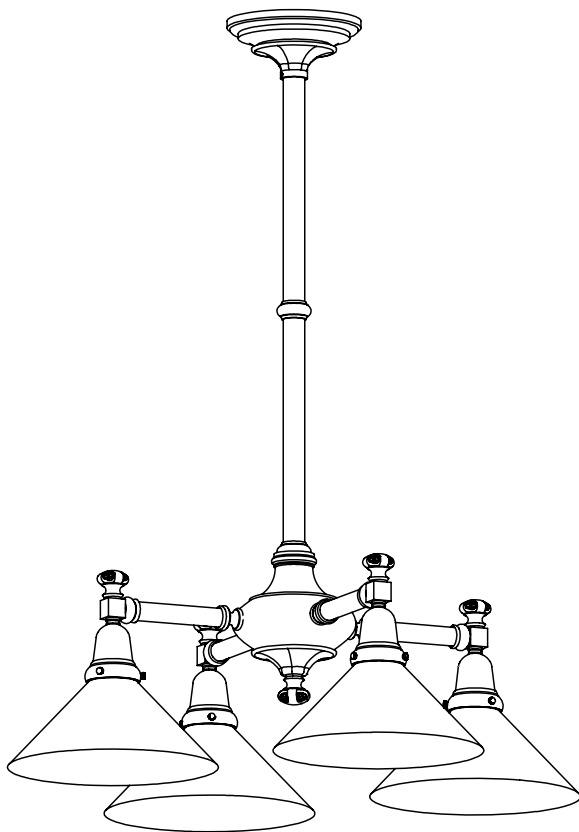

NEW CLASSICS™
Handmade in USA

FINISHES - applied by hand.

| | |
|-----------------|------------------------|
| Polished Nickel | Architectural Bronze |
| Brushed Nickel | Verdigris Patina |
| Black | Distressed Brass |
| Brushed Brass | Antique Copper |
| Polished Brass | Satin Antique Brass |
| Antique Nickel | Unlacquered Pol. Brass |
| Vintage Nickel | Architectural Iron |

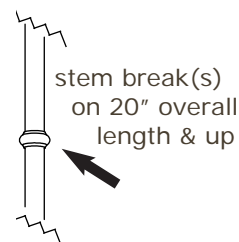

CN-524-A4-03M Shown with A384 shade(s)

Medium base screw-in sockets (4) each accept 150 W max incandescent, compact fluorescent, or LED.

GU24 base bi-pin socket available. 277V 4 pin socket alternative, inquire.

Check our website for alternative 2-1/4" shades.

Mounting plate center mounts to junction box.

Specify overall length. Minimum overall length 17".

Angled ceiling version available, inquire.

UL listed dry location.

Durably constructed of solid brass.

Made in USA by Brass Light Gallery.

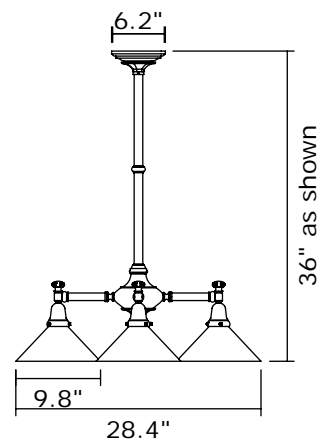

Morris Family v2.0 page 23

MORRIS™ FOUR LIGHT CHANDELIER

WITH 2-1/4" SHADE HOLDERS UP

brasslightgallery.com 800-243-9595 sales@brasslight.com

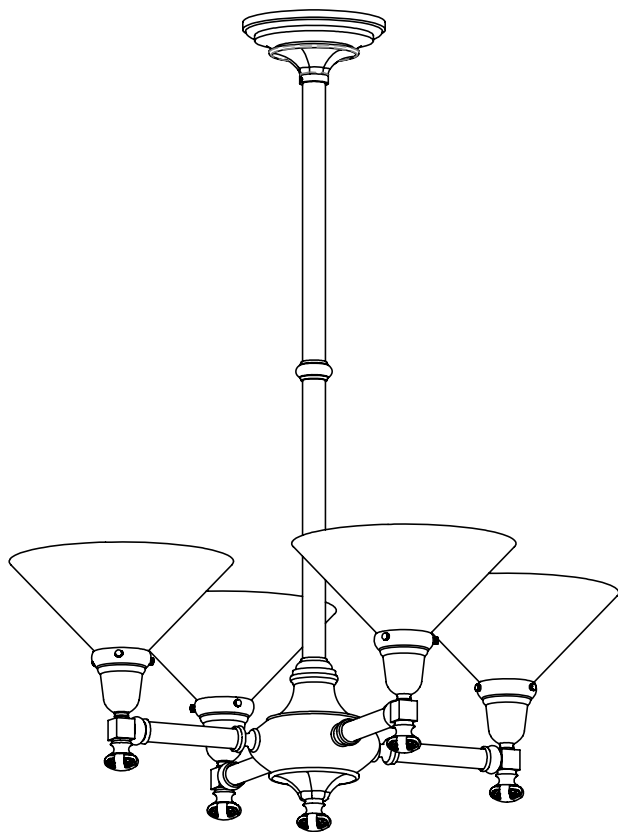

NEW CLASSICS™
Handmade in USA

FINISHES - applied by hand.

| | |
|-----------------|------------------------|
| Polished Nickel | Architectural Bronze |
| Brushed Nickel | Verdigris Patina |
| Black | Distressed Brass |
| Brushed Brass | Antique Copper |
| Polished Brass | Satin Antique Brass |
| Antique Nickel | Unlacquered Pol. Brass |
| Vintage Nickel | Architectural Iron |

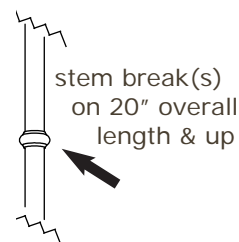

CN-524-A4-09M Shown with A384 shade(s)

Medium base screw-in sockets (4) each accept 150 W max incandescent, compact fluorescent, or LED.

GU24 base bi-pin socket available. 277V 4 pin socket alternative, inquire.

Check our website for alternative 2-1/4" shades.

Mounting plate center mounts to junction box.

Specify overall length. Minimum overall length 15".

Angled ceiling version available, inquire.

UL listed dry location.

Durably constructed of solid brass.

Made in USA by Brass Light Gallery.

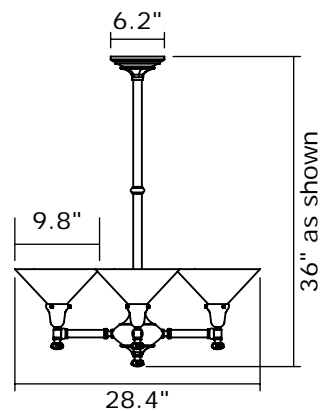

Morris Family v2.0 page 24

MORRIS™ FOUR LIGHT CHANDELIER

WITH ELECTRIC CANDLES

brasslightgallery.com 800-243-9595 sales@brasslight.com

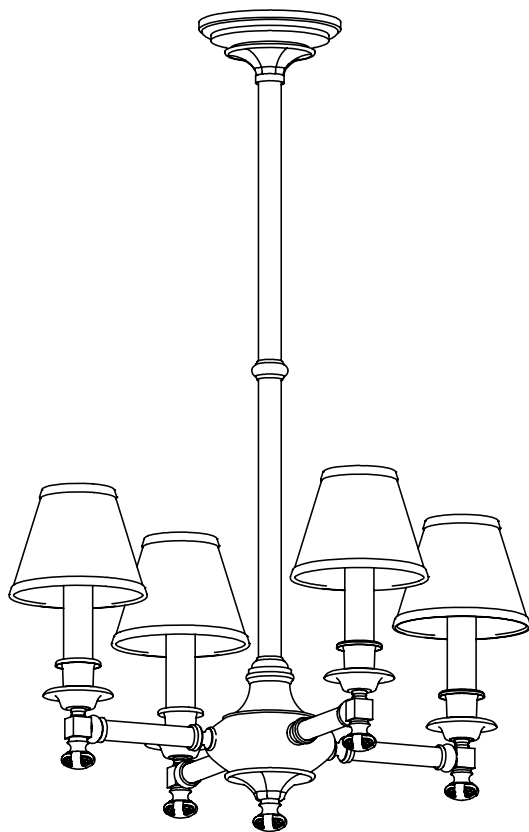

NEW CLASSICS™
Handmade in USA

FINISHES - applied by hand.

| | |
|-----------------|------------------------|
| Polished Nickel | Architectural Bronze |
| Brushed Nickel | Verdigris Patina |
| Black | Distressed Brass |
| Brushed Brass | Antique Copper |
| Polished Brass | Satin Antique Brass |
| Antique Nickel | Unlacquered Pol. Brass |
| Vintage Nickel | Architectural Iron |

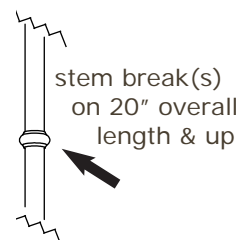

CN-524-K2-09M Shown with E210 shade(s)

Medium base screw-in sockets (4) each accept 60 W max incandescent, compact fluorescent, or LED.

GU24 base bi-pin socket available. 277V 4 pin socket alternative, inquire.

Check online for alternative clip-on shades rated at 40 to 100 watts with this fixture.

Mounting plate center mounts to junction box.

Specify overall length. Minimum overall length 19".

Angled ceiling version available, inquire.

UL listed dry location.

Durably constructed of solid brass.

Made in USA by Brass Light Gallery.

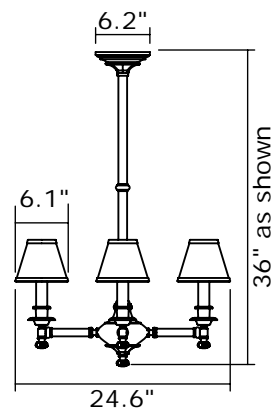

Morris Family v2.0 page 25

MORRIS™ TWO LIGHT PENDANT

WITH 2-1/4" SHADE HOLDERS DOWN

brasslightgallery.com 800-243-9595 sales@brasslight.com

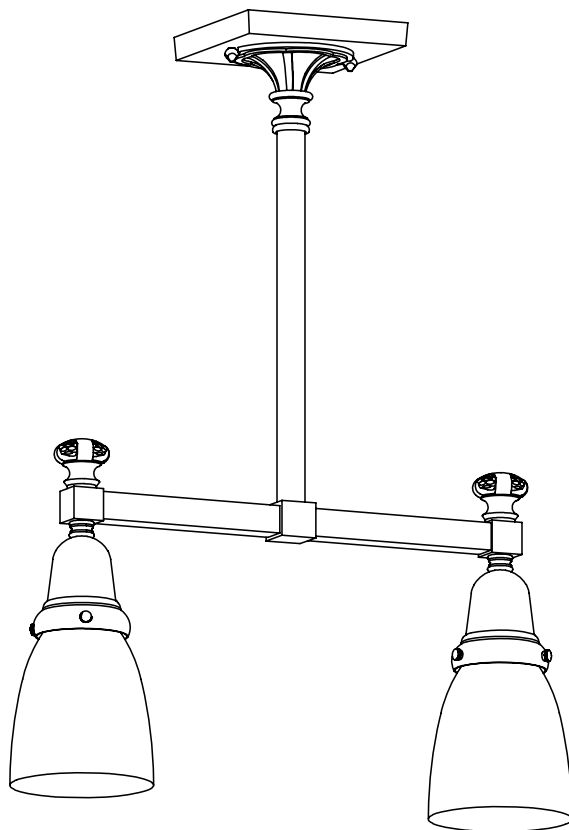

NEW CLASSICS™
Handmade in USA

FINISHES - applied by hand.

| | |
|-----------------|------------------------|
| Polished Nickel | Architectural Bronze |
| Brushed Nickel | Verdigris Patina |
| Black | Distressed Brass |
| Brushed Brass | Antique Copper |
| Polished Brass | Satin Antique Brass |
| Antique Nickel | Unlacquered Pol. Brass |
| Vintage Nickel | Architectural Iron |

CN-576-A4-03M Shown with A157 shade(s)

Medium base screw-in sockets (2) each accept 150 W max incandescent, compact fluorescent, or LED.

GU24 base bi-pin socket available. 277V 4 pin socket alternative, inquire.

Check our website for alternative 2-1/4" shades.

Mounting plate center mounts to junction box.

Specify overall length. Minimum overall length 12".

Angled ceiling version available, inquire.

UL listed dry location.

Durably constructed of solid brass.

Made in USA by Brass Light Gallery.

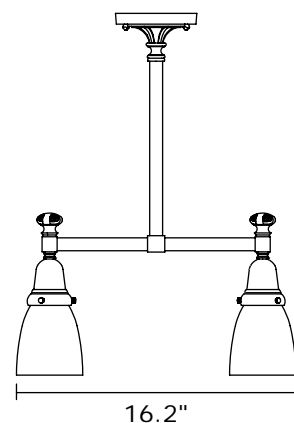
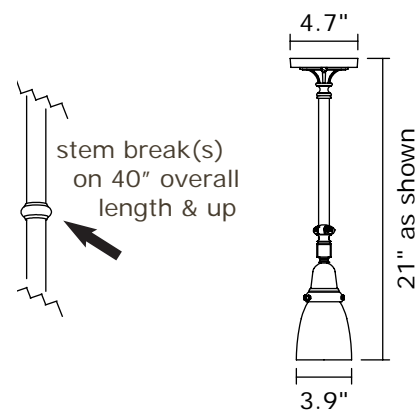

Morris Family v2.0 page 26

MORRIS™ TWO LIGHT PENDANT

WITH 2-1/4" SHADE HOLDERS UP

brasslightgallery.com 800-243-9595 sales@brasslight.com

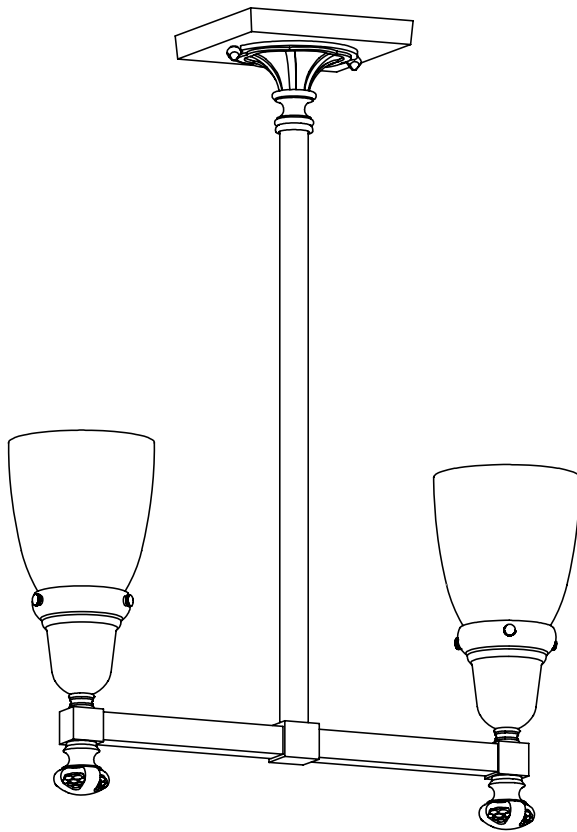

NEW CLASSICS™
Handmade in USA

FINISHES - applied by hand.

| | |
|-----------------|------------------------|
| Polished Nickel | Architectural Bronze |
| Brushed Nickel | Verdigris Patina |
| Black | Distressed Brass |
| Brushed Brass | Antique Copper |
| Polished Brass | Satin Antique Brass |
| Antique Nickel | Unlacquered Pol. Brass |
| Vintage Nickel | Architectural Iron |

CN-576-A4-09M Shown with A157 shade(s)

Medium base screw-in sockets (2) each accept 150 W max incandescent, compact fluorescent, or LED.

GU24 base bi-pin socket available. 277V 4 pin socket alternative, inquire.

Check our website for alternative 2-1/4" shades.

Mounting plate center mounts to junction box.

Specify overall length. Minimum overall length 15".

Angled ceiling version available, inquire.

UL listed dry location.

Durably constructed of solid brass.

Made in USA by Brass Light Gallery.

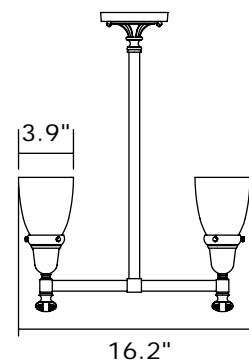
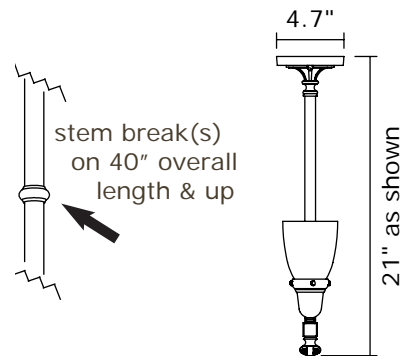

Morris Family v2.0 page 27

MORRIS™ TWO LIGHT PENDANT

WITH ELECTRIC CANDLES

brasslightgallery.com 800-243-9595 sales@brasslight.com

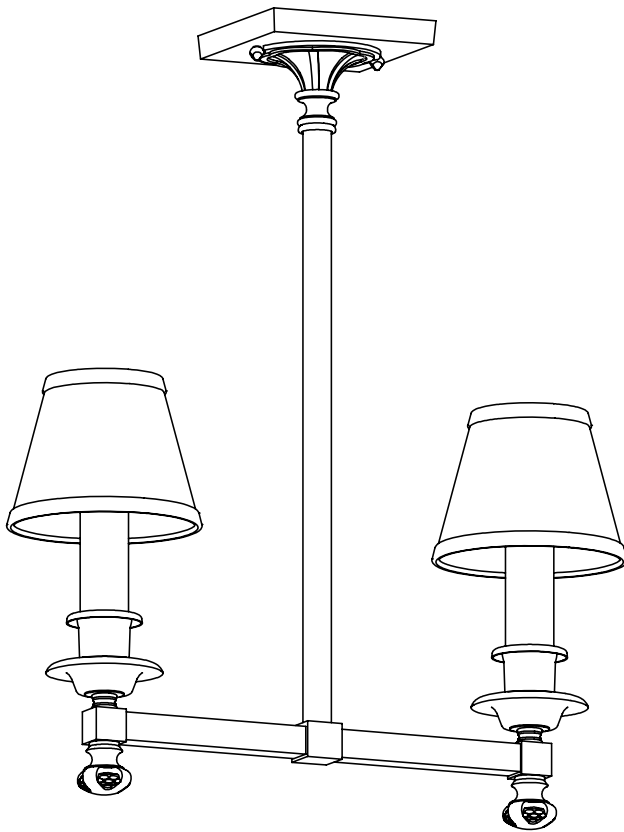

NEW
CLASSICS™
Handmade in USA

FINISHES - applied by hand.

| | |
|-----------------|------------------------|
| Polished Nickel | Architectural Bronze |
| Brushed Nickel | Verdigris Patina |
| Black | Distressed Brass |
| Brushed Brass | Antique Copper |
| Polished Brass | Satin Antique Brass |
| Antique Nickel | Unlacquered Pol. Brass |
| Vintage Nickel | Architectural Iron |

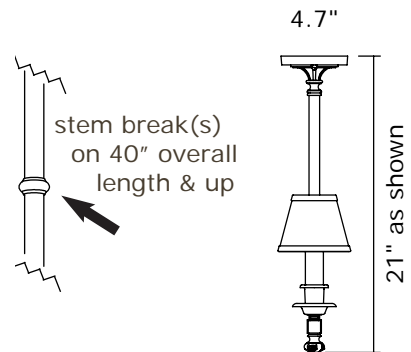

CN-576-K1-09M Shown with E231 shade(s)

Medium base screw-in sockets (2) each accept 60 W max incandescent, compact fluorescent, or LED.

GU24 base bi-pin socket available. 277V 4 pin socket alternative, inquire.

Check online for alternative clip-on shades rated at 40 to 100 watts with this fixture.

Mounting plate center mounts to junction box.

Specify overall length. Minimum overall length 14".

Angled ceiling version available, inquire.

UL listed dry location.

Durably constructed of solid brass.

Made in USA by Brass Light Gallery.

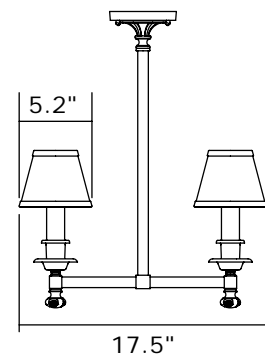

Morris Family v2.0 page 28

BRASS LIGHT GALLERY
• MILWAUKEE •

© 2013, Brass Light Gallery®